

Homestyle Traditional Canopy

Assembly Instructions

Homestyle Multi-Purpose Lean To Canopy

Assembly Instructions

Last revision: 12/07/10



Please Note:

Living Space accept no responsibility for any injury or consequential damage caused by the use of unsuitable fixings or by the installation of the product that deviates in any way from that described herein. Homestyle Multi-purpose Canopies are designed and tested to withstand a Loading of 0.65K N/m² which is suitable for domestic use. If you are installing the canopy in an exposed location please call the helpline before you commence.

Before proceeding with the assembly please ensure that the following conditions have been met:

- The wall is of solid construction – no flaking mortar or loose bricks (check with a registered builder if unsure).
- You have the correct fixings for the type of wall that you are installing the canopy onto. (Please note, no wall fixings are included)
- Check that you have sufficient space for the installation.
- Due to the weight of the product and the nature of installation TWO people with appropriate step ladders / scaffolding are required to install the Canopy.

Column Arrangement

All Homestyle canopies are supplied with 2.5m length columns as standard. We would recommend in all cases that the columns are secured using the “U” bracket to a pre – laid concrete pad. Laid approximately 400mm below ground level.

If a suitable concrete base is already present then the column can be attached to the existing base using the “U” brackets provided. If securing to an existing base, dependant upon its depth, the front height of the canopy will change and the height of the Wall Plate (as shown on the table on Page 5) should be altered accordingly. The columns can be cut to the required length using a hacksaw.

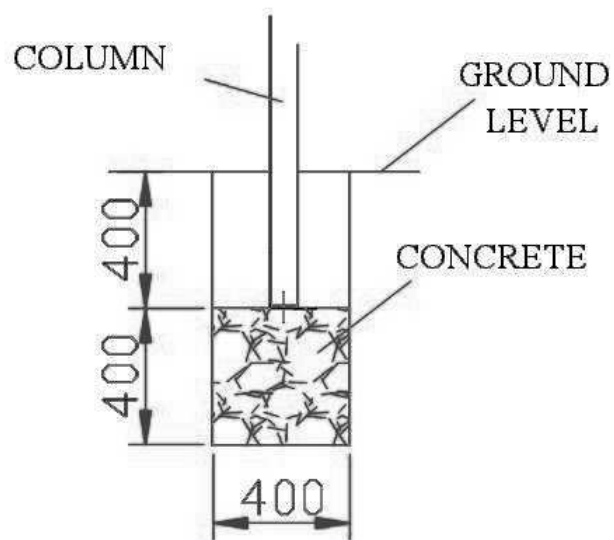

Wall Plate

Pre drill part along length (see drawing).

Drill holes 50mm in from each end and at approximately 450mm centres along the length of the wall plate. Remove any debris and sharp edges.

Fit the Rubber Gaskets (see drawing).

Use soapy water to aid rubber slide along recess in profile if required.

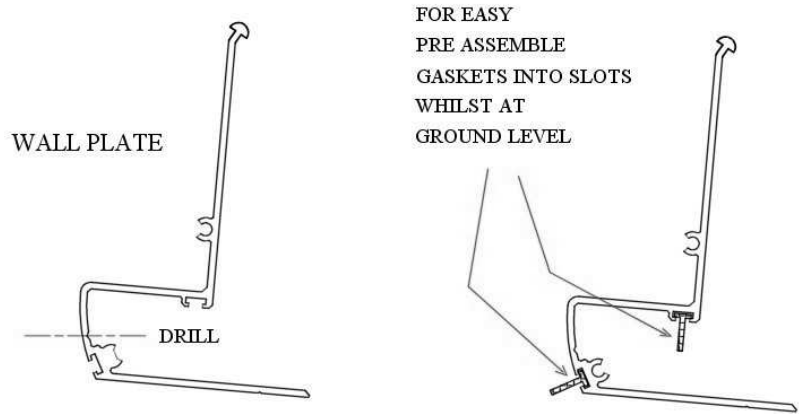

FOR EASY OF ASSEMBLY
PRE DRILL CLEARANCE HOLES
WHILE AT GROUND LEVEL
ALONG THE LENGTH OF EACH PART
(TYP 50mm IN EACH END AND 500 CENTRES)

Assemble the Wall Plate (see drawing) and secure to wall.

****Ensure the wall plate is horizontal using a spirit level.****

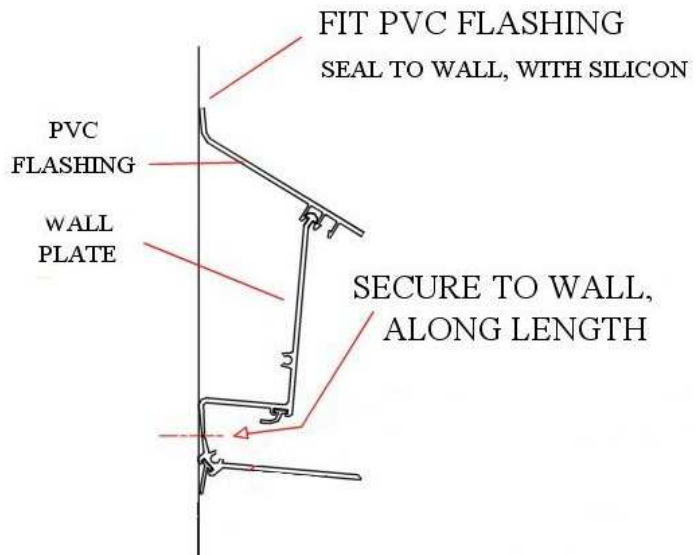

Fit wall plate end caps.

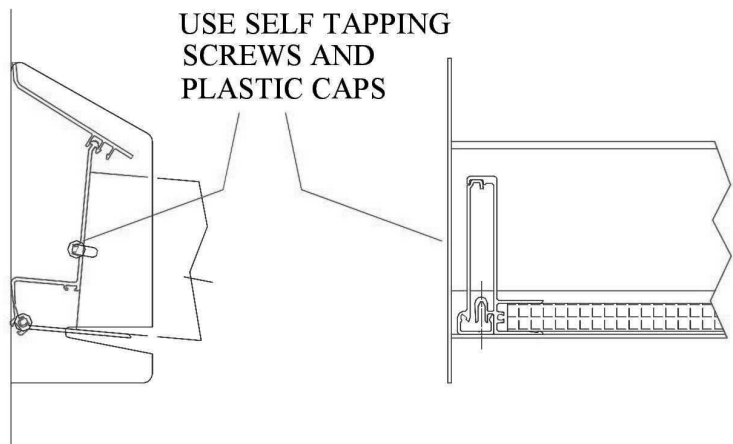

Front Support Frame Assembly

Assemble front support frame and legs as indicated.

Two shoes are to be fixed to the Eaves Beam, these locate the upper ends of the Posts. Upper shoes are supplied blank and are drilled on site.

Additional Shoes are fixed securely to the floor, in position to receive the assembled support frame.

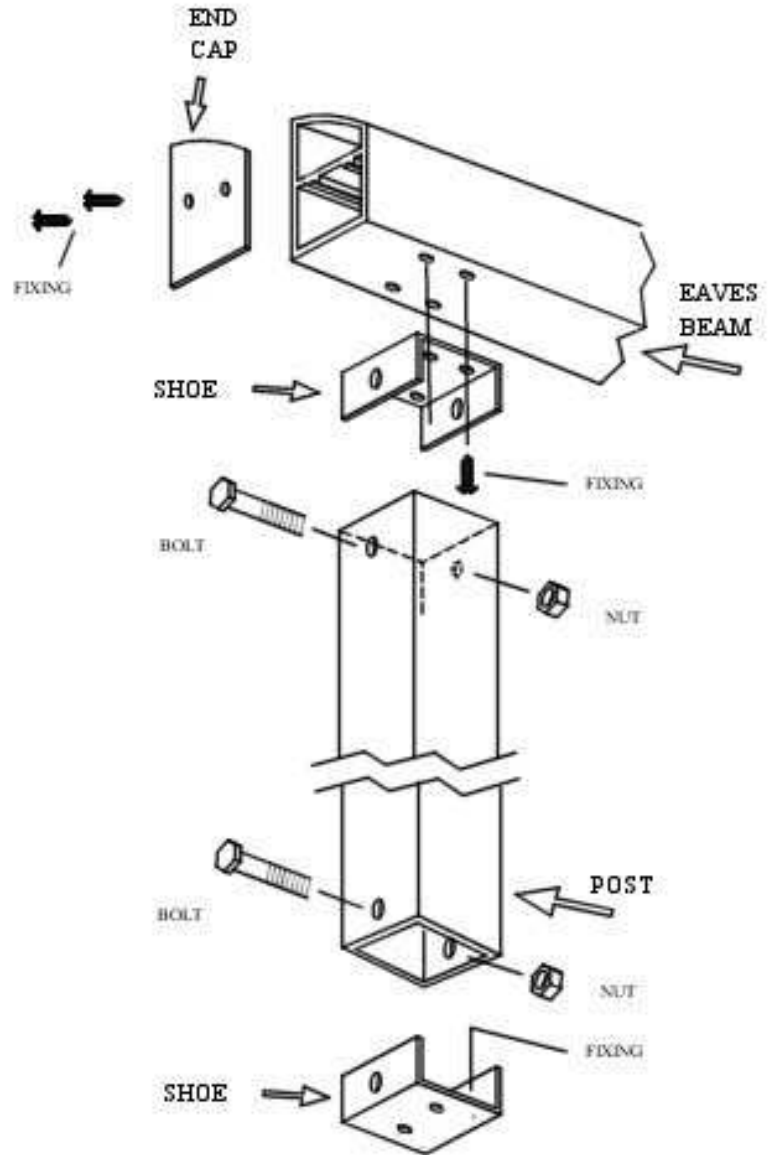

On longer lengths Eaves beams will have to be joined, see diagram right.

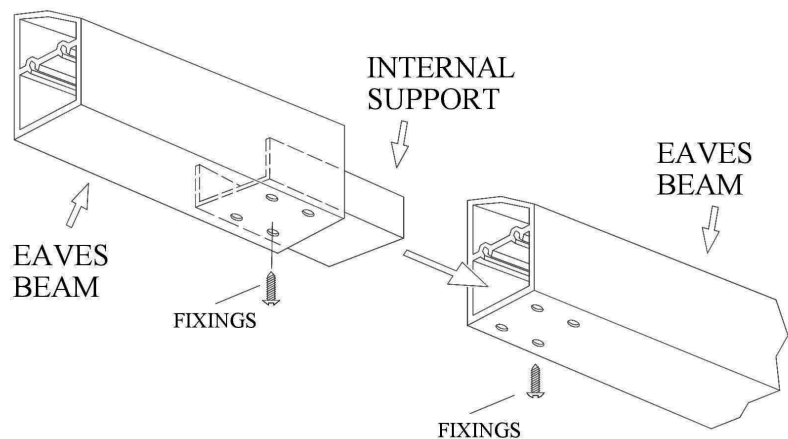

To obtain good water flow ensure the eaves beam is positioned (see diagram) with the slope away from the wall.

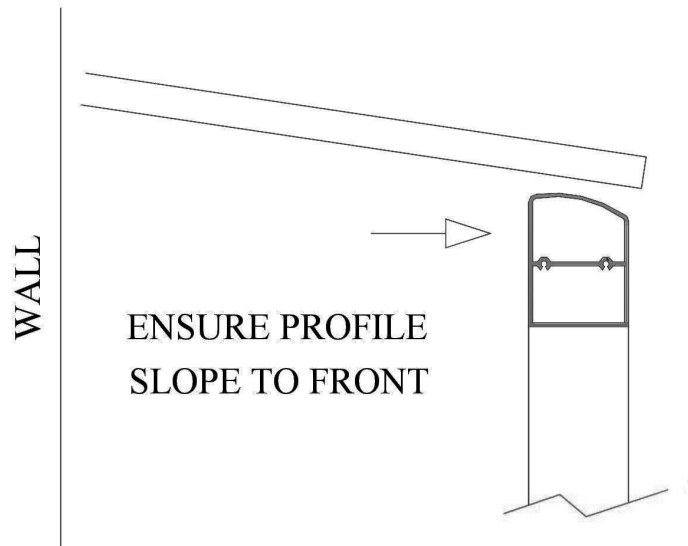

Sizes based on recommended support column length of 2100mm above ground.

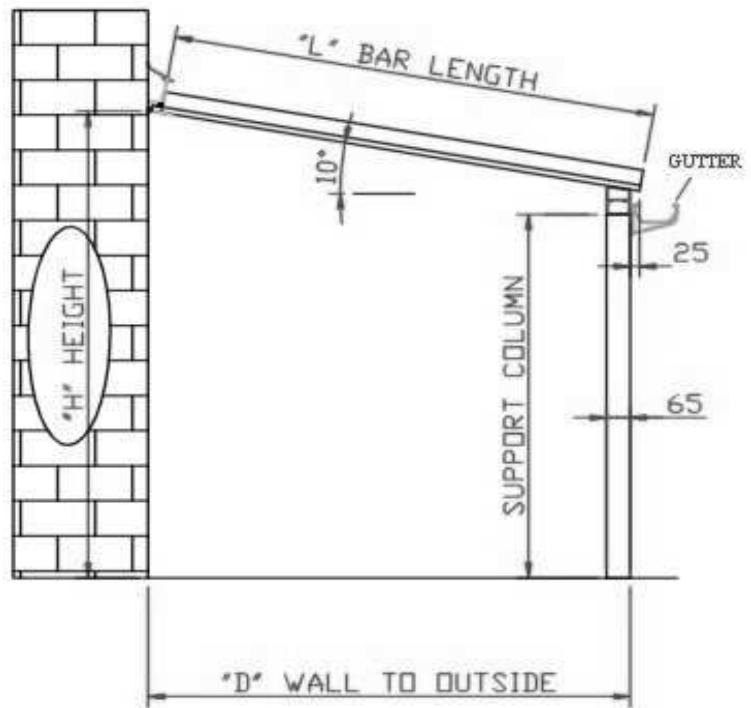

Bar Length "L"	Horizontal Distance "D"	Height to Wall Plate "H"
1475mm	1464mm	2455mm
2475mm	2449mm	2625mm
2975mm	2942mm	2715mm
3475mm	3434mm	2800mm
3975mm	3927mm	2885mm

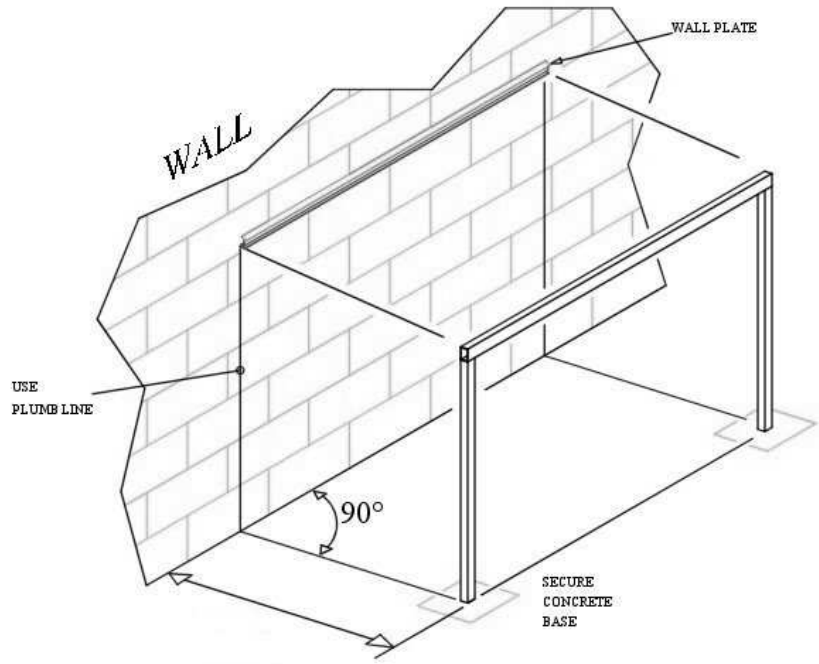

Preparation of the Glazing Panels

The Panel Fixing Packs provided contain self-tapping screws to secure the panels. Plastic screw caps are provided for use where screw heads are visible.

Lay out all panels on floor to ensure size of canopy is correct.

Pre-drill the clearance holes while at ground level along the length of each part (see drawing). Typically this is 100mm in each end and 500 centres.

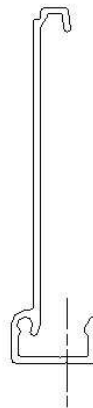

DRILL

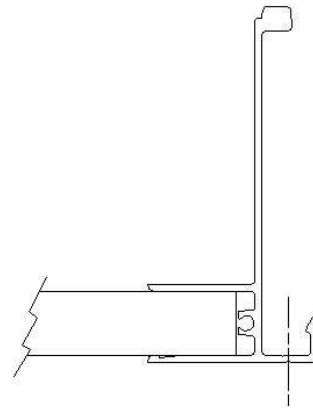

DRILL

LH END CLOSURE

Starting at the left of the canopy as you face the wall, position the Left Hand end closure.

Ensuring that it is square to the wall, secure with screws.

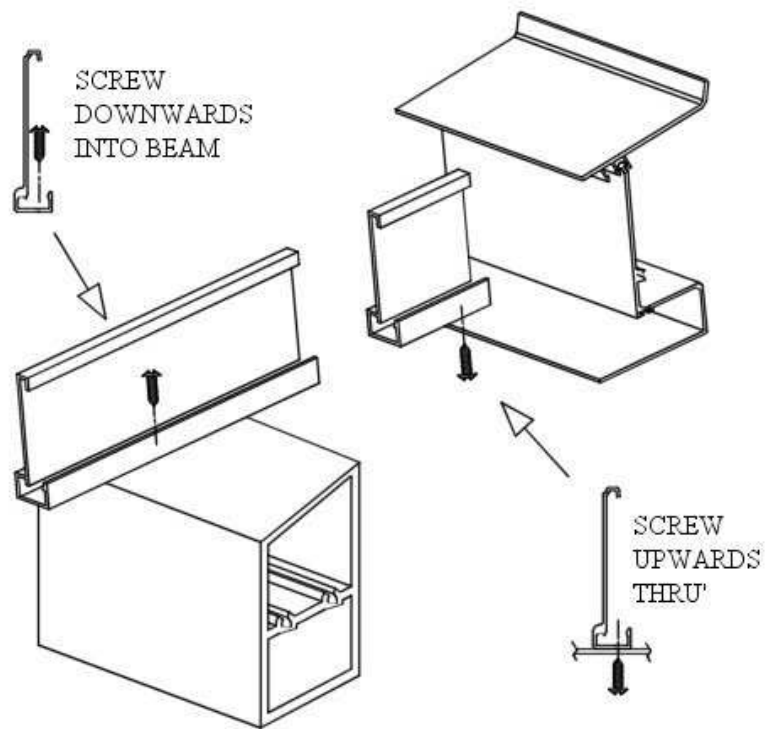

Each glazing panel has a polycarbonate protrusion of approximately 25mm this needs to be fed into the wall plate to provide a watertight seal. Ensure panel pushed fully into wall plate, front edge should be level with previously fixed part.

**SLOT ALL PROFILES TOGETHER
THEN SLIDE/PUSH UP INTO
FINAL POSITION THEN SECURE**

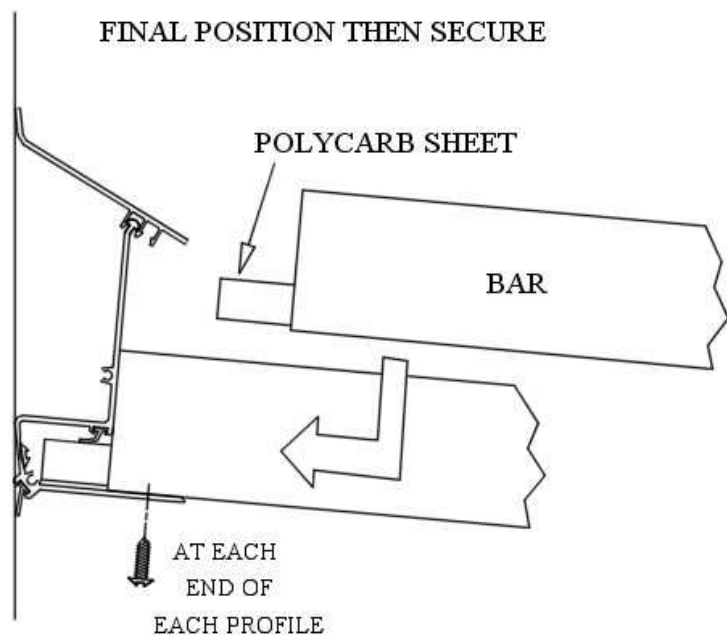

Lift one pre-assembled panel on to the roof and locate onto the previously fixed Aluminium profile.

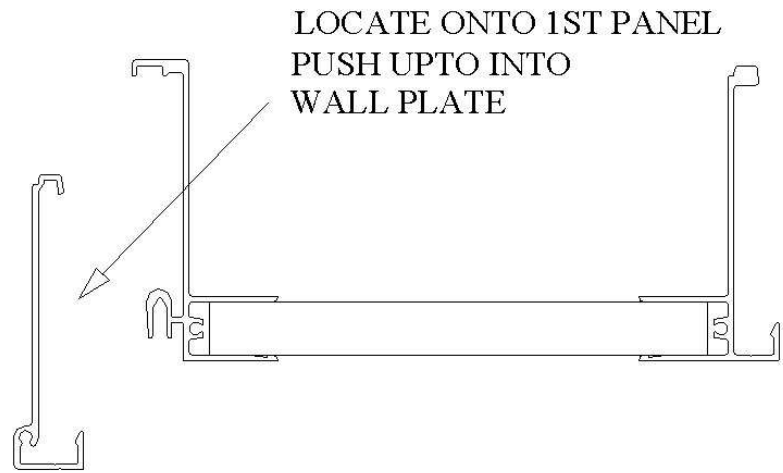

Secure along length to previous aluminium profile. At each end secure to wall plate and support frame.

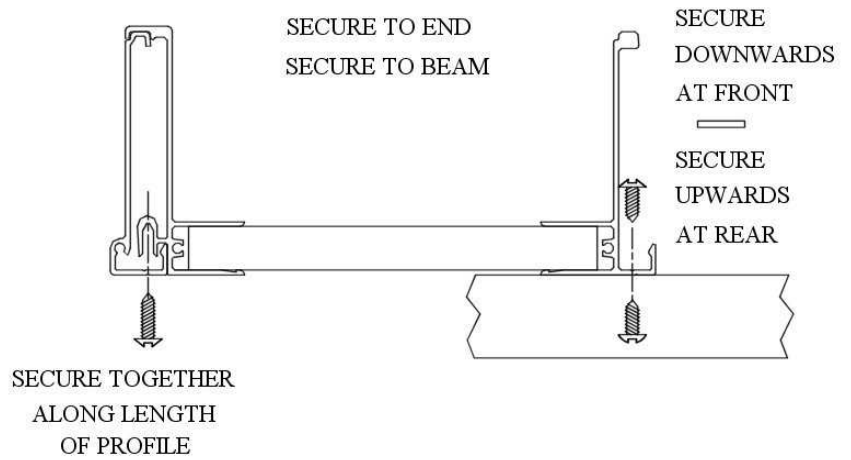

Lift one pre-assembled panels on to the roof and locate onto the previously fixed Aluminium profile.

Repeat with additional panels. Secure each as positioned, while access and fixing position within reach.

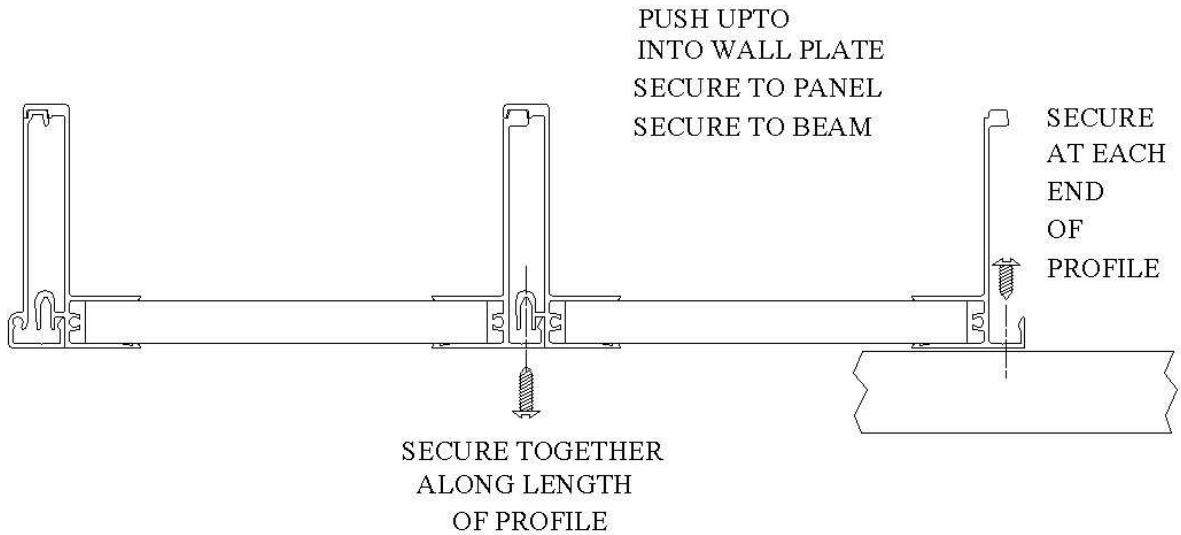
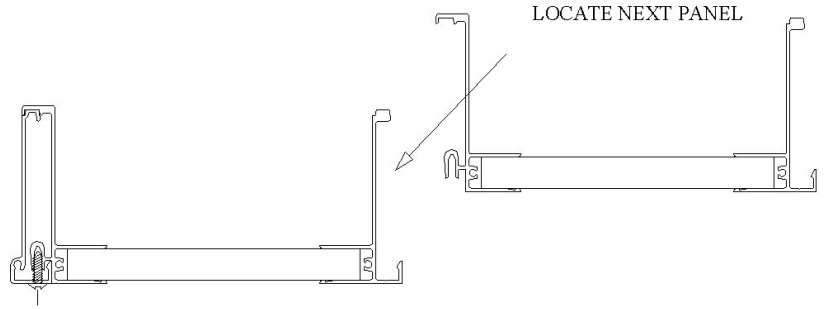

At right hand end use final single End Closure to complete appearance, fix through angled edge as previous, along length.

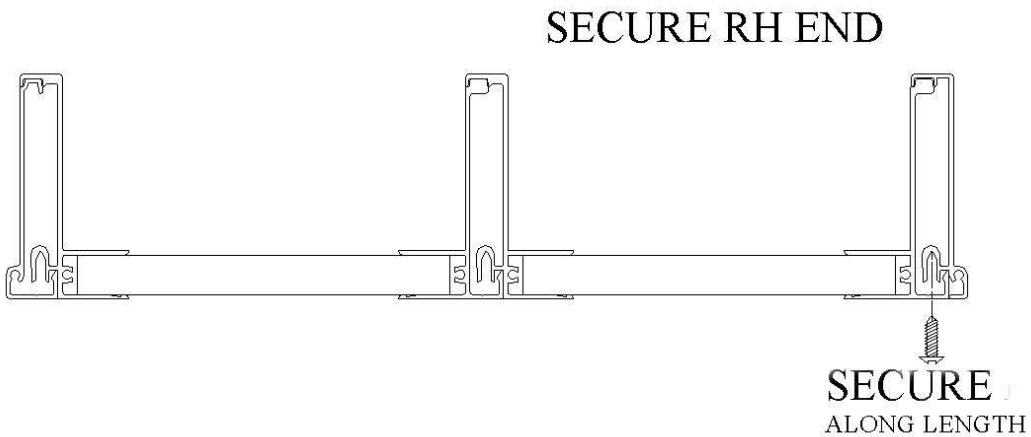
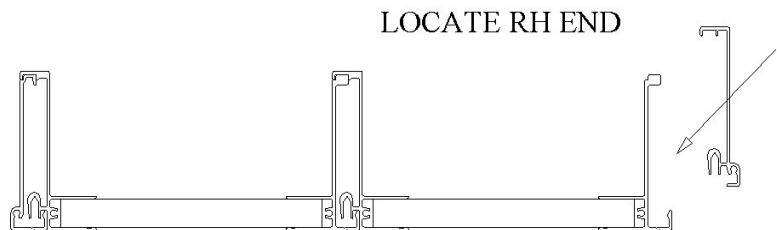

You can now fix the Rafter End Caps using the screws and caps provided.

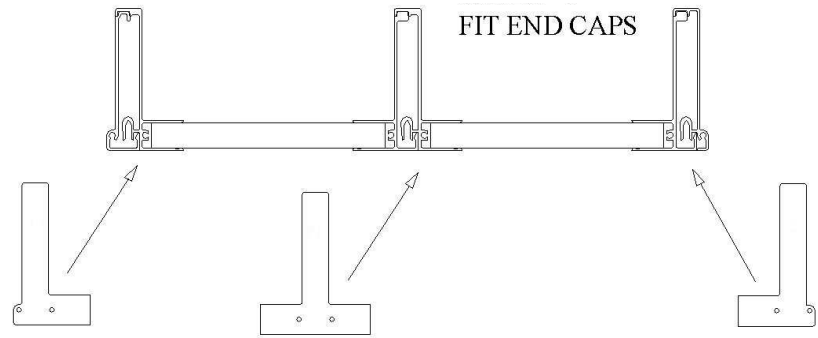

Installing the Rainwater System

Please Note:- A slight angle is required along both the front and side gutters. This is to ensure that the water flows along the gutter and into the down-pipe.

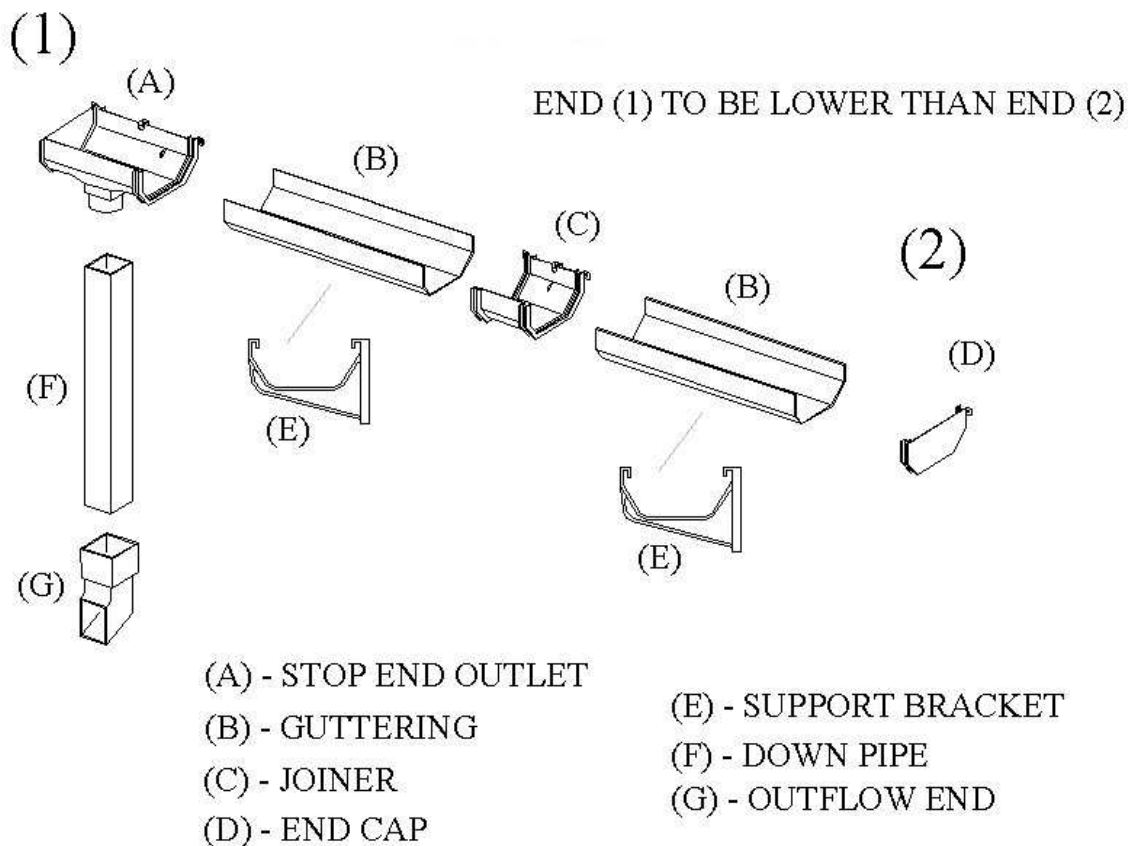

Decide which end of the canopy the down spout is to be (where the flow of water won't be a problem). This will then determine the position of the "Stop End Outlet". Blank off relevant end.

Position the bracket closet to end (2) use 1 screw, this will allow for adjustment to the angle. Fit guttering into bracket.

Using Stop end Outlet as guide mark guttering if it requires cutting down to size. Add additional sections if required using "Joining" piece. So as whole roof will have guttering under its edge for water disposal but not too much as will look unsightly and also be unsupported.

With the correct length guttering assembled, clip on and evenly space the remaining support brackets along the complete length.

With end (2) supported in the fixed bracket, end (1) is to be 10mm to 20mm lower than end (2). This will ensure flow towards the “Down Spout” Note: - to large a difference will on heavy rain fall cause the water to flow over the end instead of going down the spout.

With the gutter in position, mark all brackets and fixing holes. This will ensure that when the brackets are fixed in position with screws that the guttering will remain straight and undistorted, as the brackets must be at the right height.